

NYFGbY 0.6/1 kV

Copper Conductor, PVC Insulated,SWA, PVC Sheathed

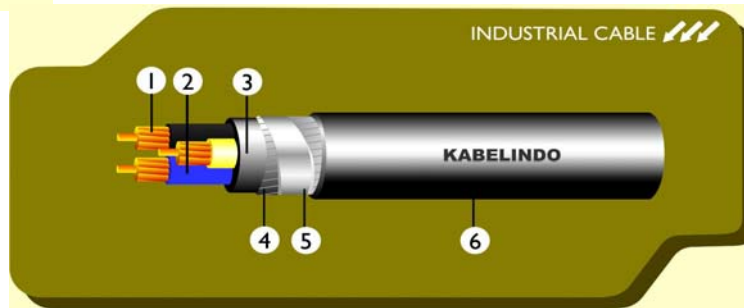

- 1. Conductor : Annealed Copper wire
- 2. Insulation : Extruded PVC
- 3. Filler : Extruded PVC
- 4/5. Armour : Galvani
- 6. Sheath : Extruded PVC

PVC LOW VOLTAGE CABLE

TECHNICAL DATA

Spec Specification : SPLN 43 -2 : 1994,
IEC 60502 - 1 : 1997

APL Multicores power and control cable used for indoor and outdoor installation direct burial

Cu Conductor Shape : re = Circular Sc
rm = Circular Sl

DCV DC Test Voltage : 8,5 kV for 5 min

DIMENSIONAL DATA

5 CORES

SIZE	No.of wire and Shaped Of Conductor		Nominal Thickness		Approximately		Min. Bending Diameter	Std. Length per reel
	pcs	shape	Insulation	Outer Sheath	Overall Diameter	Net. Weight		
1.5	1	re	0.8	1.8	16.6	503	589	1000
	7	rm			16.3	521		
2.5	1	re	1	1.8	17	573	623	
	7	rm			17.6	619	678	
4	1	re	1	1.8	19.3	777	837	
	7	rm			20.1	831	881	
6	1	re	1	1.8	20.7	939	1009	
	7	rm			21.6	1005	1092	
10	7	rm	1.2	1.9	24	1323	1403	
16	7	rm			26.8	1750	1873	
25	7	rm	1.2	2	31.3	2519	2655	
35	7	rm			34.7	3158	3344	
50	19	rm	1.4	2.1	39.7	4117	4291	500

ELECTRICAL DATA

SIZE	DC Resistance at 20°C		Current Carrying Capacity at 30°C		Conductor Short Circuit Current Capacity at :			DC Voltage Test
	Conductor (Max)	Insulation (Min)	In Ground	In Air	0.1 second	0.5 second	1.0 second	
mm ²	Ohm/km	M.ohm.km	A	A	kA	kA	kA	

1.5	12.1	50	24	18	0.67	0.30	0.21	8.5 kV for 5 minutes
2.5	7.41		32	25	1.12	0.50	0.36	
4	4.61		41	34	1.80	0.80	0.57	
6	3.08		52	44	2.69	1.20	0.85	
10	1.83		69	60	4.49	2.01	1.42	
16	1.15	40	89	80	7.18	3.21	2.27	
25	0.727		116	105	11.23	5.02	3.55	
35	0.524		138	130	15.72	7.03	4.97	
50	0.387	30	165	160	22.45	10.04	7.10	

